

F

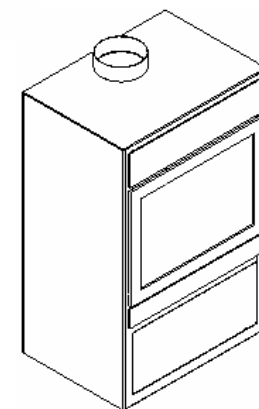

type	kW	a	b	c	d	e1	e2	f	g x h	B/L x H x D/P	kg
F25	29 kW (25 000 kcal/h)	710	0	616	486	135,5 / 160	114	180	470 x 317	542 x 340 x 413	189
opt.: houtvak/bac à bois		1000	290	616	486	135,5 / 160	114	180	470 x 317	542 x 340 x 413	217
F30	23 / 35 kW (20 000 / 30 000 kcal/h)	650	0	687	486	135,5 / 160	110	180	541 x 275	613 x 295 x 413	196
opt.: houtvak/bac à bois		950	300	687	486	135,5 / 160	110	180	541 x 275	613 x 295 x 413	227
F40S	23 / 35 kW (20 000 / 30 000 kcal/h)	785	0	687	486	135,5 / 160	120	180	541 x 380	613 x 400 x 413	199
opt.: houtvak/bac à bois		1085	300	687	486	135,5 / 160	120	180	541 x 380	613 x 400 x 413	230
F40H	46 kW (40 000 kcal/h)	850	0	687	486	135,5 / 160	120	180	541 x 380	613 x 400 x 413	222
opt.: houtvak/bac à bois		1150	300	687	486	135,5 / 160	120	180	541 x 380	613 x 400 x 413	241
F45	52 kW (45 000 kcal/h)	850	0	687	586	145,5 / 160	120	200	541 x 380	613 x 400 x 513	256
opt.: houtvak/bac à bois		1150	300	687	586	145,5 / 160	120	200	541 x 380	613 x 400 x 513	293
F50S	52 kW (45 000 kcal/h)	1000	0	870	650	223	155	250	690 x 445	784 x 525 x 571	380
opt.: houtvak/bac à bois		1300	300	870	650	223	155	250	690 x 445	784 x 525 x 571	433
F50H	58 kW (50 000 kcal/h)	1075	0	870	650	223	155	250	690 x 445	784 x 525 x 571	424
opt.: houtvak/bac à bois		1375	300	870	650	223	155	250	690 x 445	784 x 525 x 571	476

F-900mm

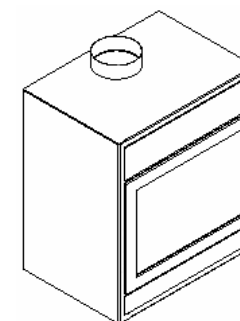
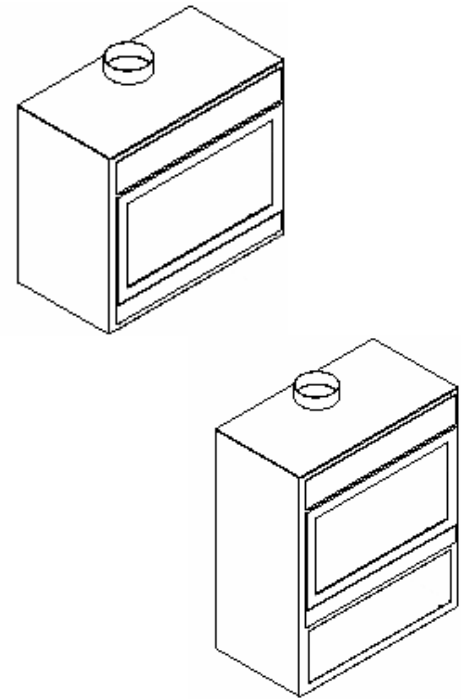
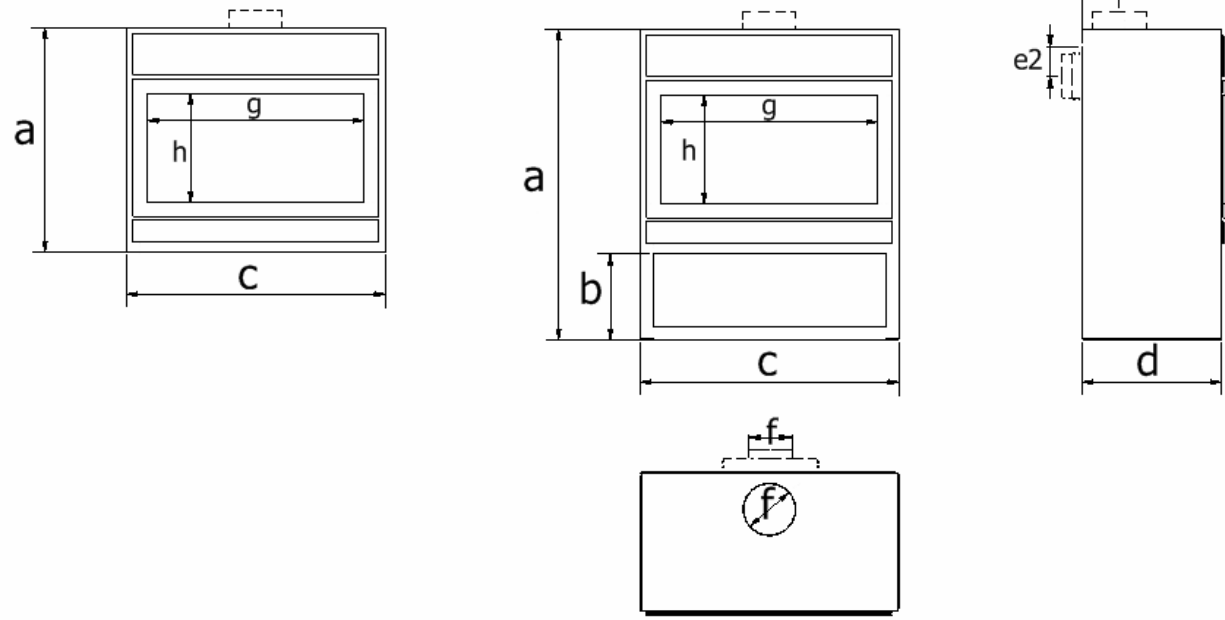

type	kW	a	b	c	d	e1	e2	f	g x h	B/L x H x D/P	kg
F25-900mm	29 kW (25 000 kcal/h)	710	0	900	486	145,5 / 160	114	200	754 x 317	826 x 340 x 413	223
opt.: houtvak/bac à bois		1000	290	900	486	145,5 / 160	114	200	754 x 317	826 x 340 x 413	262
F30-900mm	23 / 35 kW (20 000 / 30 000 kcal/h)	650	0	900	486	145,5 / 160	110	200	754 x 275	826 x 295 x 413	231
opt.: houtvak/bac à bois		950	300	900	486	145,5 / 160	110	200	754 x 275	826 x 295 x 413	272
F40S-900mm	23 / 35 kW (20 000 / 30 000 kcal/h)	785	0	900	486	145,5 / 160	120	200	754 x 380	826 x 400 x 413	235
opt.: houtvak/bac à bois		1085	300	900	486	145,5 / 160	120	200	754 x 380	826 x 400 x 413	276
F40H-900mm	46 kW (40 000 kcal/h)	850	0	900	486	145,5 / 160	120	200	754 x 380	826 x 400 x 413	262
opt.: houtvak/bac à bois		1150	300	900	486	145,5 / 160	120	200	754 x 380	826 x 400 x 413	303
F45-900mm	52 kW (45 000 kcal/h)	850	0	900	586	223	120	250	754 x 380	826 x 400 x 513	297
opt.: houtvak/bac à bois		1150	300	900	586	223	120	250	754 x 380	826 x 400 x 513	346
F50S-900mm	52 kW (45 000 kcal/h)	1000	0	900	650	223	155	250	720 x 445	814 x 525 x 571	449
opt.: houtvak/bac à bois		1300	300	900	650	223	155	250	720 x 445	814 x 525 x 571	503
F50H-900mm	58 kW (50 000 kcal/h)	1075	0	900	650	223	155	250	720 x 445	814 x 525 x 571	501
opt.: houtvak/bac à bois		1375	300	900	650	223	155	250	720 x 445	814 x 525 x 571	546

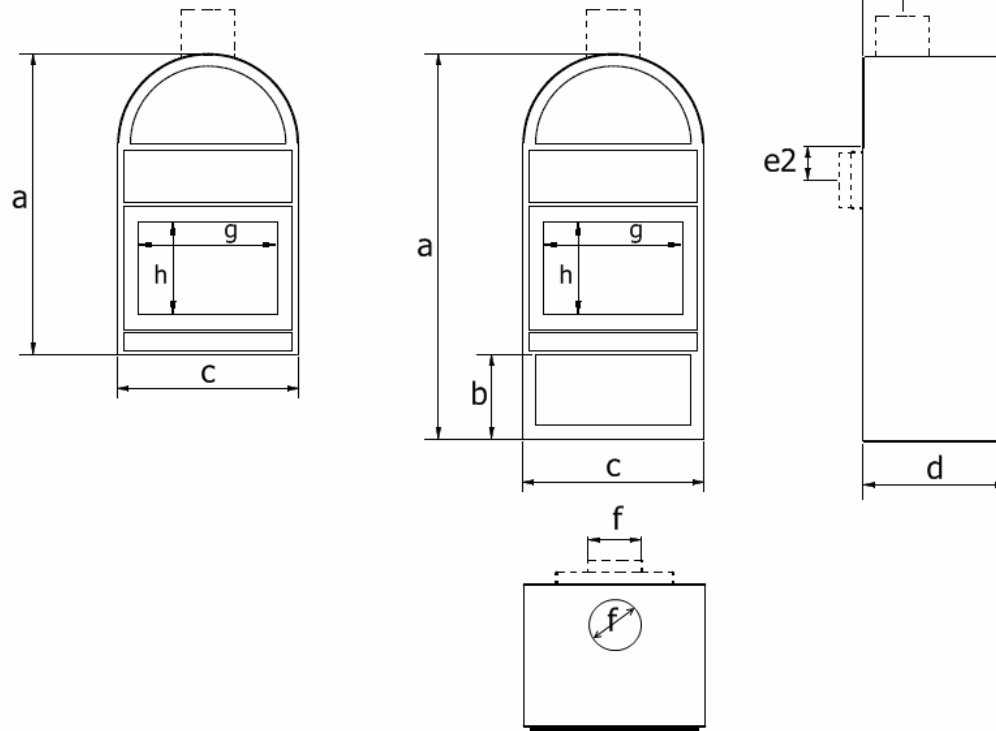

F rondo

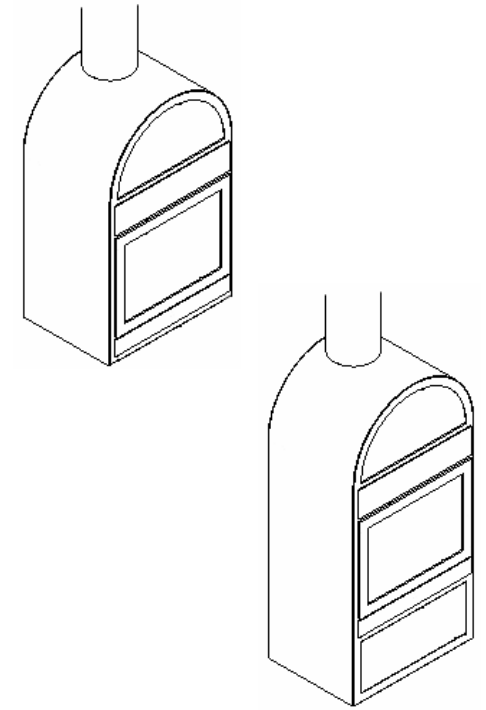

type	kW	a	b	c	d	e1	e2	f	g x h	B/L x H x D/P	kg
F25 rondo	29 kW (25 000 kcal/h)	1018	0	616	486	160	114	180	470 x 317	542 x 340 x 413	204
opt.: houtvak/bac à bois		1308	290	616	486	160	114	180	470 x 317	542 x 340 x 413	232
F30 rondo	23 / 35 kW (20 000 / 30 000 kcal/h)	993,5	0	687	486	160	110	180	541 x 275	613 x 295 x 413	213
opt.: houtvak/bac à bois		1293,5	300	687	486	160	110	180	541 x 275	613 x 295 x 413	244
F40S rondo	23 / 35 kW (20 000 / 30 000 kcal/h)	1128,5	0	687	486	160	120	180	541 x 380	613 x 400 x 413	216
opt.: houtvak/bac à bois		1428,5	300	687	486	160	120	180	541 x 380	613 x 400 x 413	247
F40H rondo	46 kW (40 000 kcal/h)	1193,5	0	687	486	160	120	180	541 x 380	613 x 400 x 413	239
opt.: houtvak/bac à bois		1493,5	300	687	486	160	120	180	541 x 380	613 x 400 x 413	264
F45 rondo	52 kW (45 000 kcal/h)	1193,5	0	687	586	160	120	200	541 x 380	613 x 400 x 513	314
opt.: houtvak/bac à bois		1493,5	300	687	586	160	120	200	541 x 380	613 x 400 x 513	385
F50S rondo	52 kW (45 000 kcal/h)	1435	0	870	650	223	155	250	690 x 445	784 x 525 x 571	438
opt.: houtvak/bac à bois		1735	300	870	650	223	155	250	690 x 445	784 x 525 x 571	438
F50H rondo	58 kW (50 000 kcal/h)	1510	0	870	650	223	155	250	690 x 445	784 x 525 x 571	429
opt.: houtvak/bac à bois		1810	300	870	650	223	155	250	690 x 445	784 x 525 x 571	482

Prisma

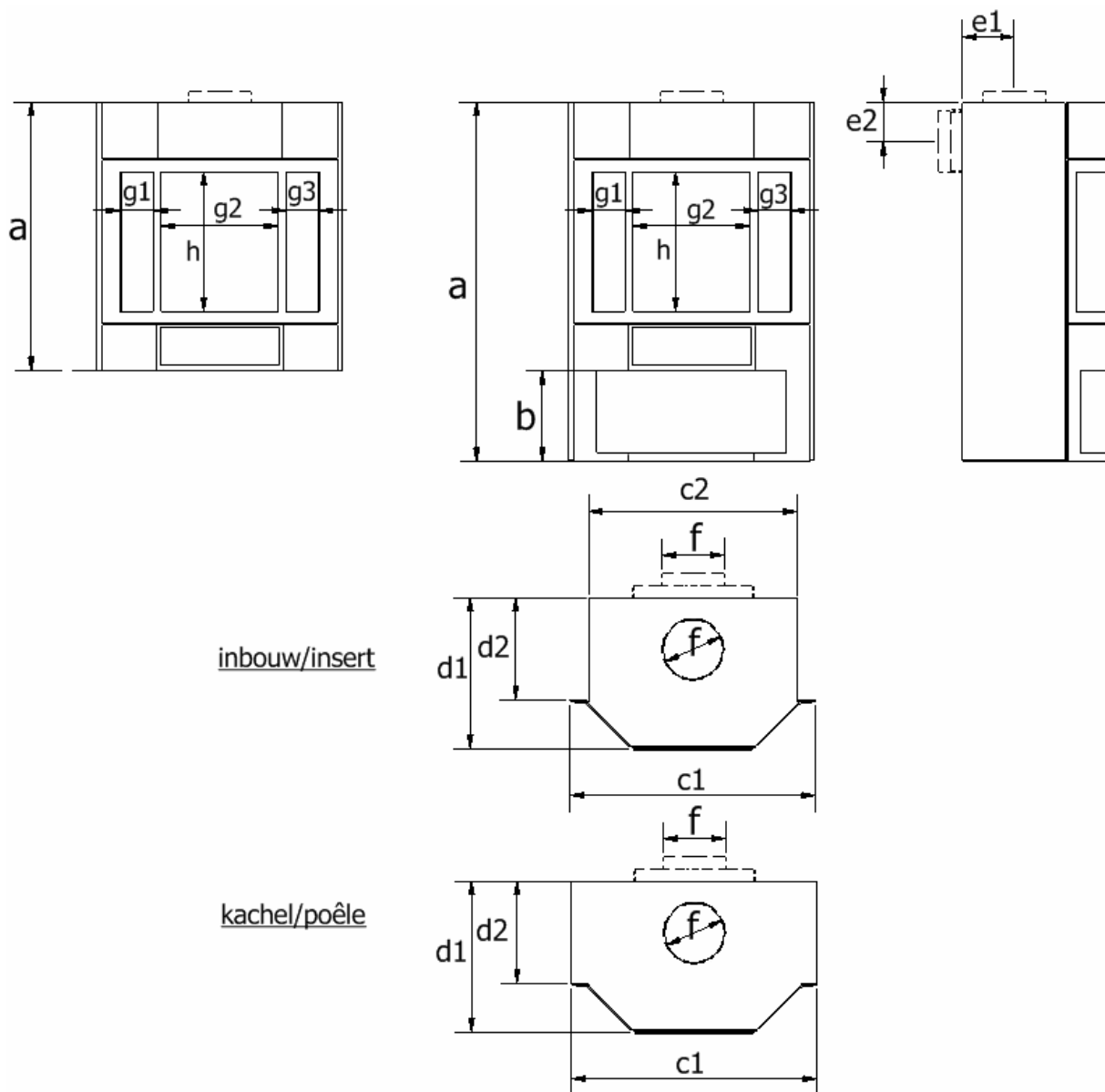

inbouw/insert

kachel/poêle

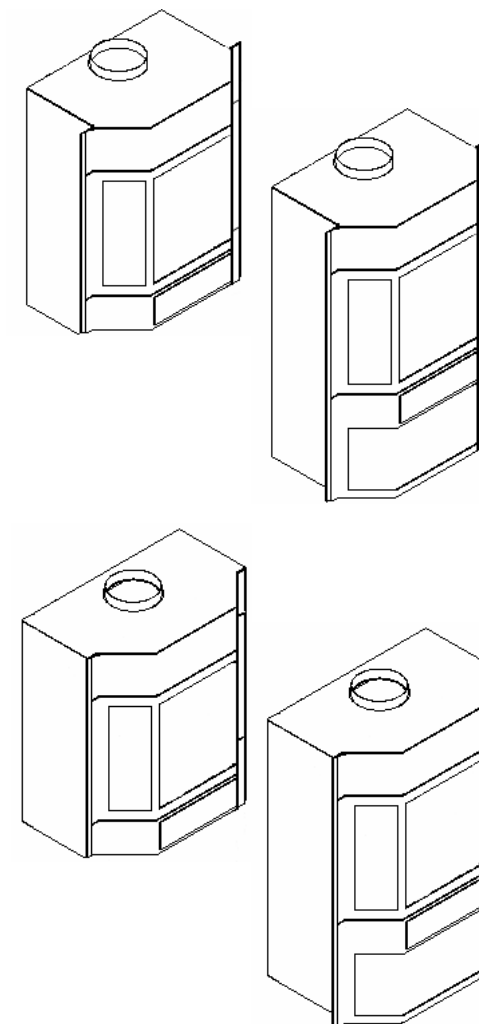

type	kW	a	b	c1	c2	d1	d2	e1	e2	f	(g1+g2+g3) x h	B/L x H x D/P	kg
Prisma30 H785	23 / 35 kW (20 000 / 30 000 kcal/h)	785	0	807	687	493	337	126 / 170	130	200	(155+385+155) x 360	613 x 405 x (303-408)	195
opt.: houtvak/bac à bois		1085	300	807	687	493	337	126 / 170	130	200	(155+385+155) x 360	613 x 405 x (303-408)	230
Prisma45	52 kW (45 000 kcal/h)	850	0	807	687	593	437	143 / 220	130	200	(155+385+155) x 360	613 x 405 x (403-508)	298
opt.: houtvak/bac à bois		1150	300	807	687	593	437	143 / 220	130	200	(155+385+155) x 360	613 x 405 x (403-508)	333

Tornado

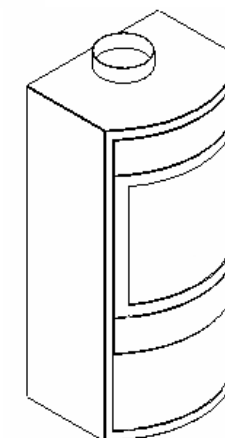
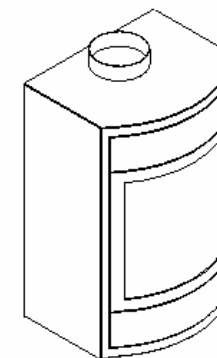
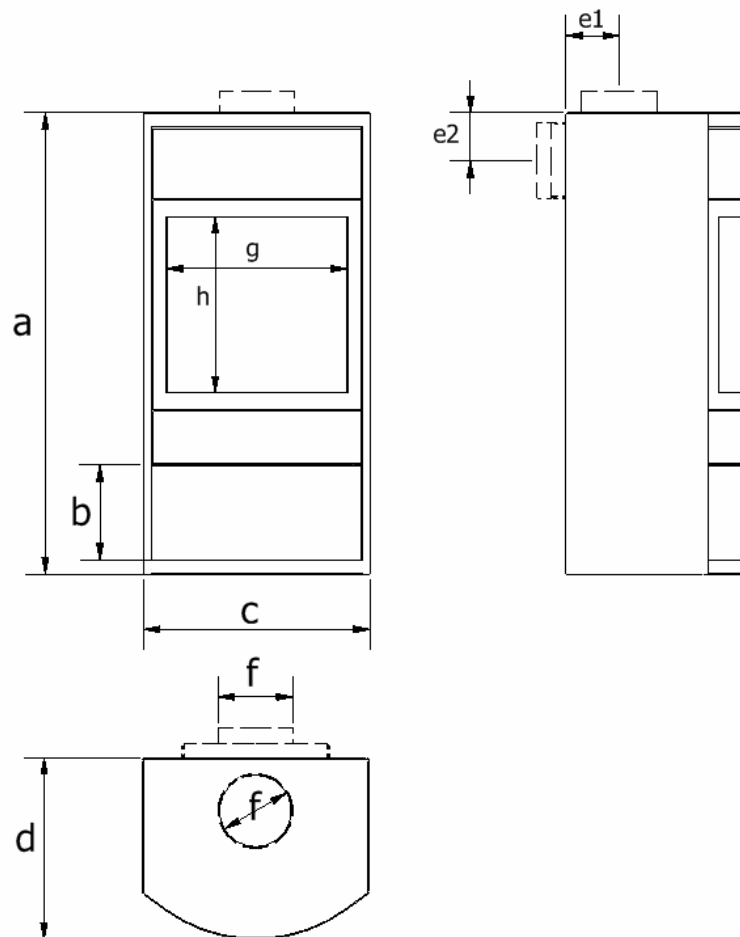
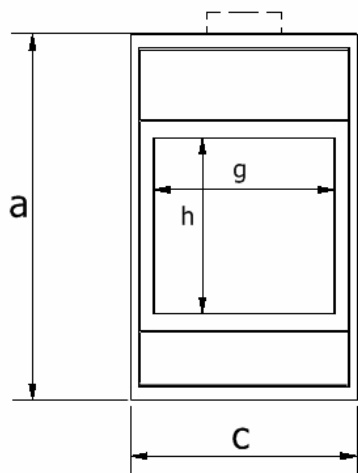

type	kW	a	b	c	d	e1	e2	f	g x h	B/L x H x D/P	kg
Tornado25	25 kW (22 000 kcal/h)	996	0	616	495	145	130	200	516 x 480	542 x 500 x (305-413)	212
opt.: houtvak/bac à bois		1256	260	616	495	145	130	200	516 x 480	542 x 500 x (305-413)	229
Tornado30	30 kW (26 000 kcal/h)	996	0	616	495	145	130	200	516 x 480	542 x 500 x (305-413)	215
opt.: houtvak/bac à bois		1256	260	616	495	145	130	200	516 x 480	542 x 500 x (305-413)	232
Tornado40S	23 / 35 kW (20 000 / 30 000 kcal/h)	996	0	687	535	145	130	200	567 x 480	613 x 500 x (307-453)	218
opt.: houtvak/bac à bois		1256	260	687	535	145	130	200	567 x 480	613 x 500 x (307-453)	238
Tornado40H	46 kW (40 000 kcal/h)	996	0	687	535	145	130	200	567 x 480	613 x 500 x (307-453)	238
opt.: houtvak/bac à bois		1256	260	687	535	145	130	200	567 x 480	613 x 500 x (307-453)	258
Tornado45	52 kW (45 000 kcal/h)	1036	0	687	635	145	130	200	578 x 480	613 x 460 x (406-553)	292
opt.: houtvak/bac à bois		1296	260	687	635	145	130	200	578 x 480	613 x 460 x (406-553)	312

Tornado

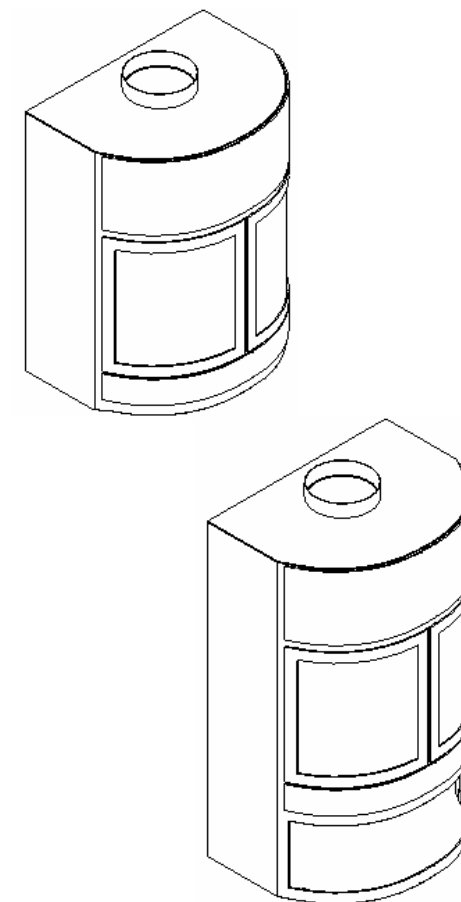
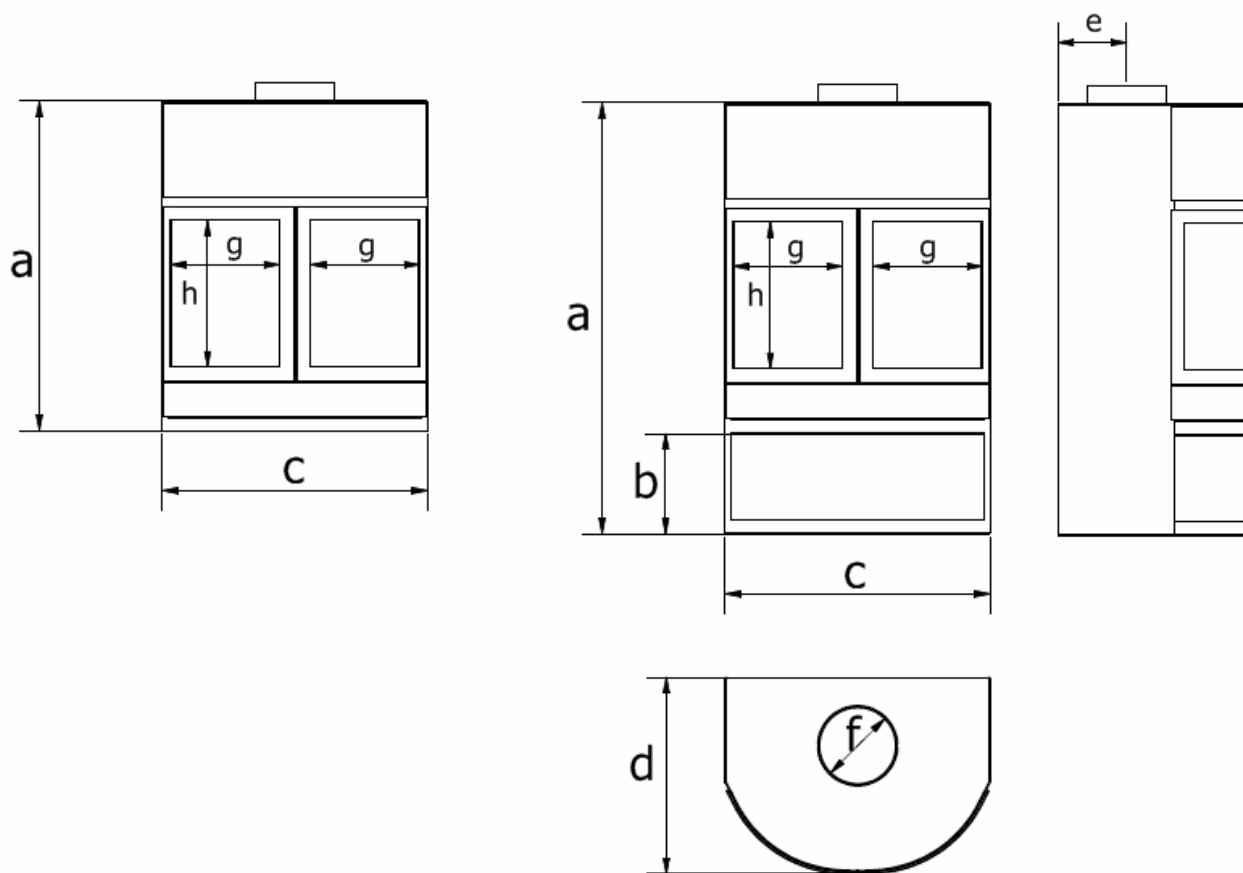

type	kW	a	b	c	d	e	f	g x h	B/L x H x D/P	kg
Tornado50S	52 kW (45 000 kcal/h)	1087	0	870	647	225	250	439 x 480	778 x 500 x (259-562)	382
opt.: houtvak/bac à bois		1415	328	870	647	225	250	439 x 480	778 x 500 x (259-562)	416
Tornado50H	58 kW (50 000 kcal/h)	1087	0	870	647	225	250	439 x 480	778 x 500 x (259-562)	419
opt.: houtvak/bac à bois		1415	328	870	647	225	250	439 x 480	778 x 500 x (259-562)	453

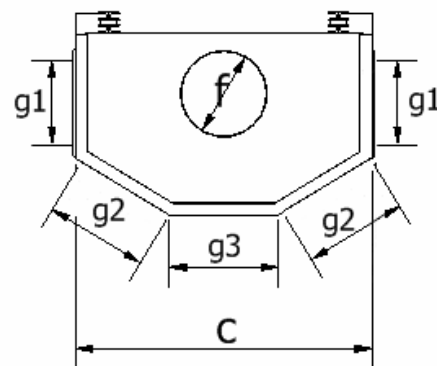
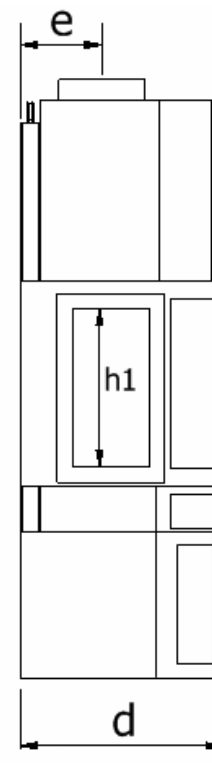
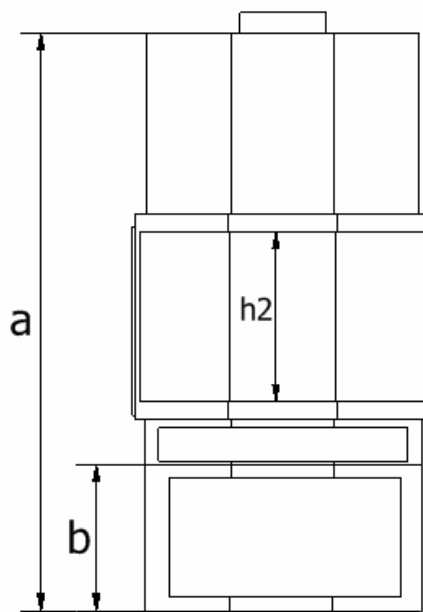
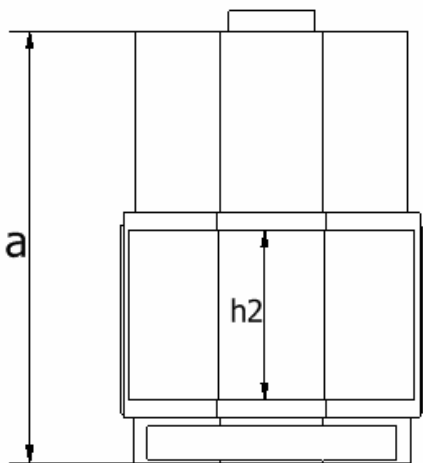

L

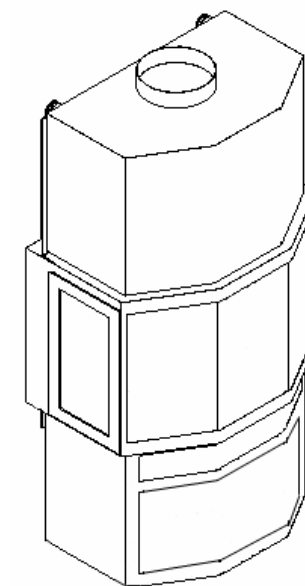
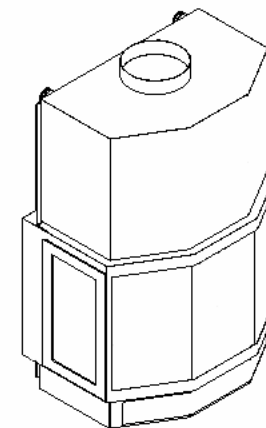

type	kW	a	b	c	d	e	f	(g1+g2+g3) x (h1+h2)	B/L x H x D/P	kg
L30	23 / 35 kW (20 000 / 30 000 kcal/h)	1270	0	870	540	180	250	(225+296+316) x (406+500)	724 x 760 x (430-448)	347
opt.: houtvak/bac à bois		1570	300	870	540	180	250	(225+296+316) x (406+500)	724 x 760 x (430-448)	391
L40	46 kW (40 000 kcal/h)	1270	0	870	540	180	250	(225+296+316) x (406+500)	724 x 704 x (430-448)	373
opt.: houtvak/bac à bois		1570	300	870	540	180	250	(225+296+316) x (406+500)	724 x 704 x (430-448)	417

Largo

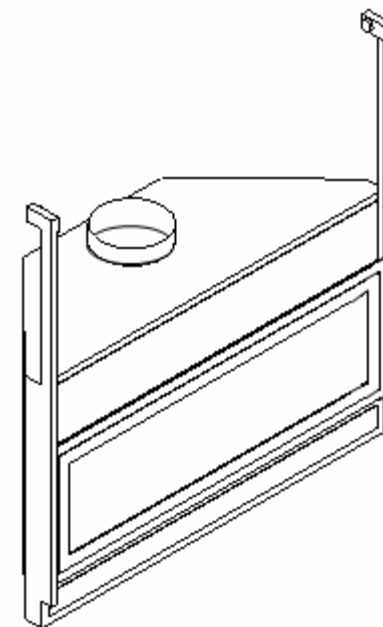
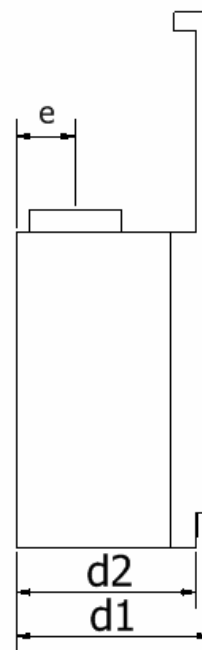
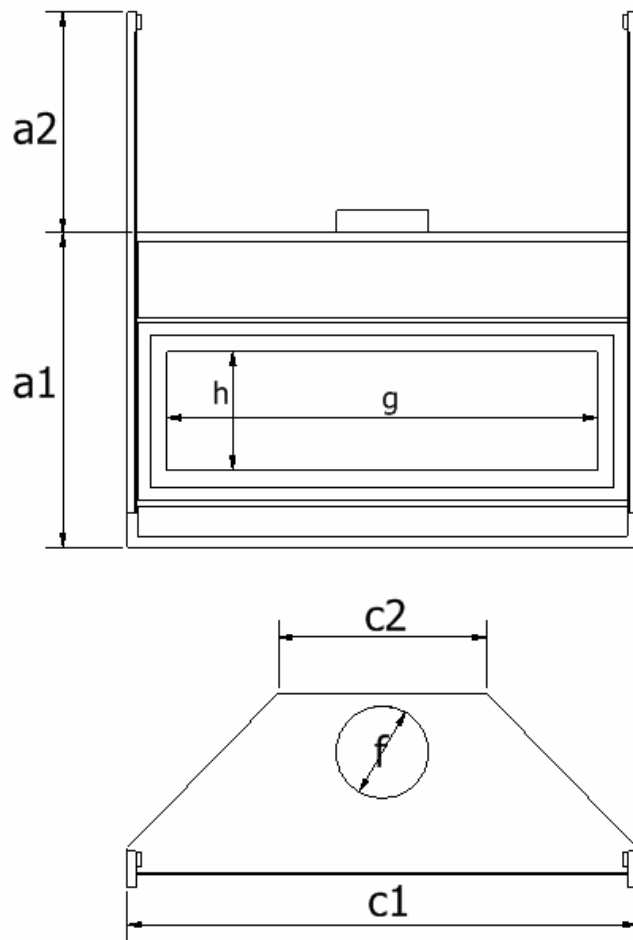

type	kW	a1	a2	c1	c2	d1	d2	e	f	g x h	B/L x H x D/P	kg
Largo30	23 / 35 kW (20 000 / 30 000 kcal/h)	850	700	1374	565	531	486	130	250	1164 x 320	1300 x 400 x 413	317
Largo40	46 kW (40 000 kcal/h)	850	700	1374	565	531	486	130	250	1164 x 320	1300 x 400 x 413	343
Largo50S	52 kW (45 000 kcal/h)	1075	765	1374	870	695	650	130	250	1164 x 405	1288 x 525 x 571	503
Largo50H	58 kW (50 000 kcal/h)	1075	765	1374	870	695	650	130	250	1164 x 405	1288 x 525 x 571	540